

Long Gage Sensor Structural Health Monitoring system

Opto-Electronic Engineering Laboratory Corporation

1. Features

- Monitoring the degradation and Detecting the cracks of the concrete structures for Long-term
- The optical fiber strain sensors with FBG(Fiber Bragg Grating) for the concrete structures
- High performance for the lightning protection and for the electromagnetic Noise
- Low cost systems with the differential FBG optical circuit having no wavelength meter equipment
- The temperature correction as for FBG via the differential FBG optical complementary circuits
- Mounting the optical temperature sensor internally
- The software process distinguishing the temperature-strain and the stress-strain for the concrete

2. Engineering Applications

- The monitoring systems for the health and degradation of the concrete bridge
- The monitoring systems for the deformation of the tunnel
- The structural health monitoring system of the Dam
- The strain sensor system of the concrete constructions
- The crack-detection and crack-monitoring system of the concrete constructions

3. Basic Sensor Settings

The Basic Sensor Settings consist of the Long Gage Sensor main unit, the optical fiber termination box, the optical source / the photodiode monitor module, PC application software. These are shown in the Pic-1.

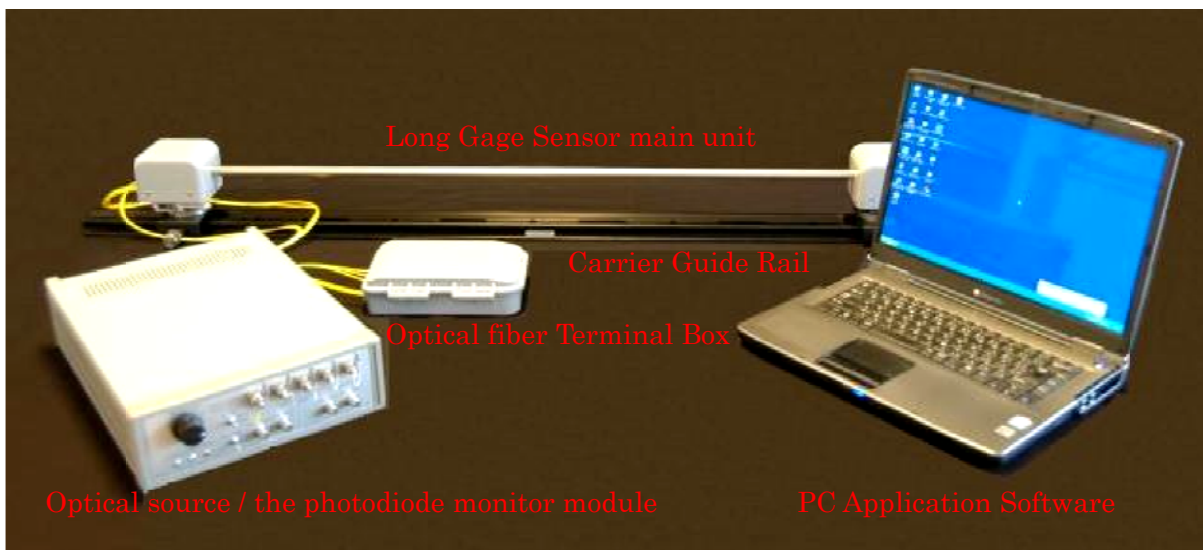

Pic-1 Basic Sensor Settings
(PC body is optional)

It is shown the dimensions of these parts in Fig-1 to in Fig-3 (unit ; mm)

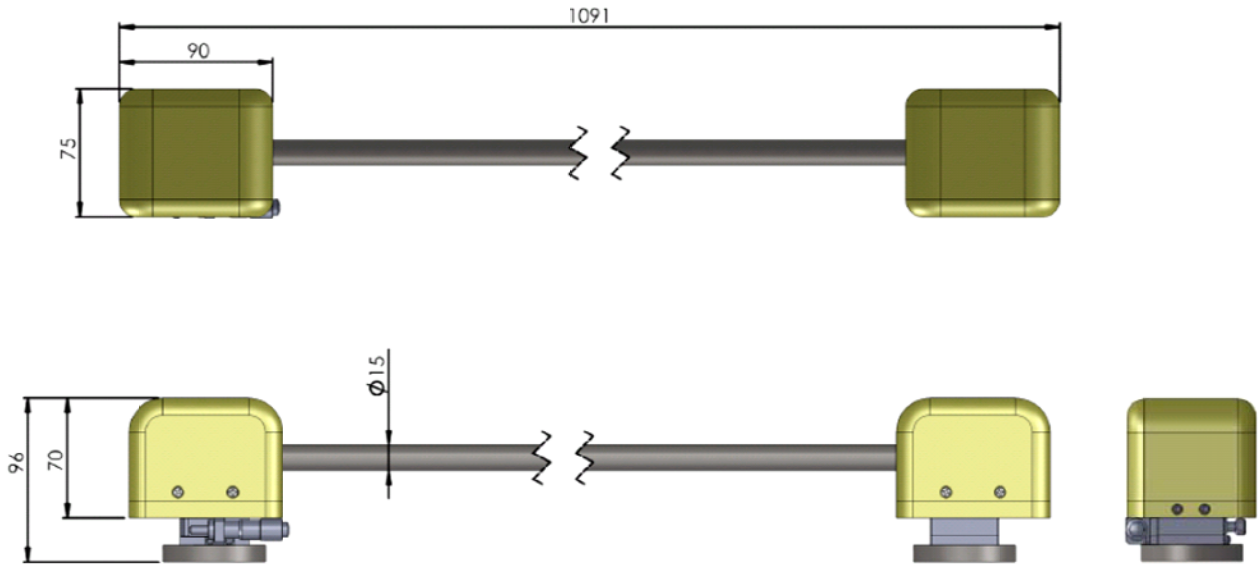

Fig-1 the dimensions of the Long Gage Sensor main unit (L=1091mm)

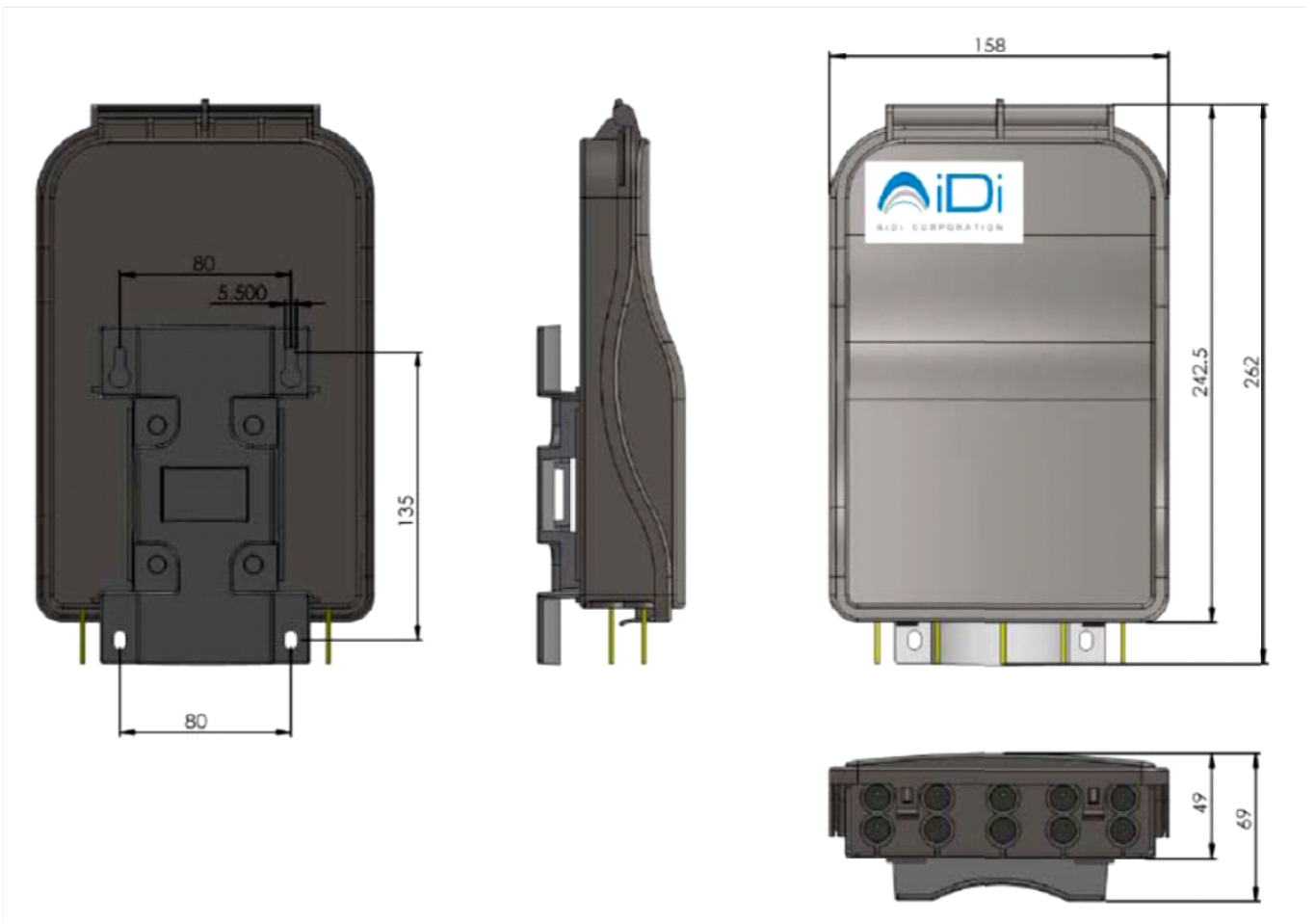

Fig-2 the dimensions of the Optical fiber Terminal Box



Pic-2 outward form of the Optical source / the photodiode monitor module

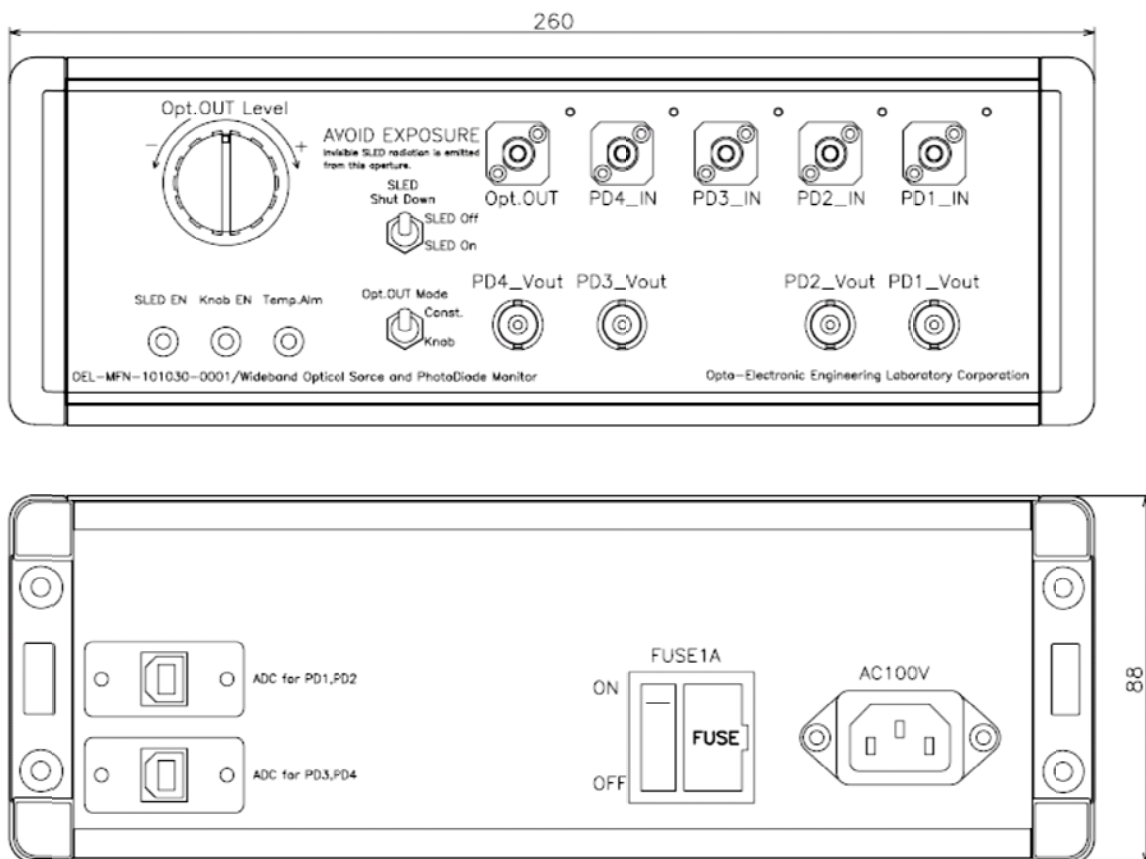

Fig-3 the dimensions of the Optical source / the photodiode monitor module
(260mm*88mm*350mm)

4. Description

Our sensor system called the long gage sensor provides the solutions of measuring the strain and of monitoring the degradation and of detecting the crack as for the concrete structures such as the buildings, the bridges, the dam, the tunnels.

The concrete material is very strong to the compressive stress-strain, but is very weak to the tensile stress-strain. So it is very important for the concrete structural objects to monitor their strains. Our Long Gage Sensor Structural Health Monitoring system provides very useful and high-performance solutions for monitoring the degradation of the concrete structural objects.

Our system applies the FBG (Fiber Bragg Grating) sensor. The FBG is One-dimensional optical fiber filter with the periodic refractive index structure, which reflects the specific optical wavelengths and changes the reflection wavelength of filter as to the periodic changes derived from external strain forces. The equations of the FBG wavelength deviations by the strain forces and by the temperature deviations, is shown below.

$$\frac{\delta\lambda_B}{\lambda_B} = \left(\frac{1}{n} \cdot \frac{\partial n}{\partial T} + \alpha_s \right) \cdot \delta T + G_F \cdot \varepsilon_s \quad (\text{eq.1})$$

Here, λ_B ; filter wavelength of FBG, $\lambda_B = 1550$ [nm], n ; refractive index, $n \doteq 1.45$,
 α_s ; temperature coefficient, $\alpha_s = 0.55$ [u-strain/ deg C], ε_s ; external stress strain [u-strain],
 G_F ; conversion coefficient of strain, $G_F = 0.78$, δT ; temperature deviation [deg C]

By (eq.1), it is easy to understand the fact that the FBG's strain component as for the temperature deviation is accounted so much. So it is needed for the FBG sensor systems to do temperature calibration. And more, the general FBG sensor systems need the expensive optical wavelength measurement equipments such as the optical spectrum analyzer, BOTDR.

Our long gage sensor applies the epoch-making strain measurement method, called the differential FBG optical circuits shown in Fig-4 which needs no-optical wavelength measurement and is having the good cost performance and is having the good-performance temperature correction via the differential FBG optical complementary circuits. The differential FBG optical circuit follows the equation (eq.2). The first term of (eq.2) indicates the temperature deviation of refractive index, the second term indicates the thermal expansion of the optical fibers, the third term indicates the external stress-strain. If the complementary circuit is having the complete operations, the first term and second term of (eq.2) disappear. The FBG is mounted in the long gage sensor, and measures the average strain value (displacement) between the long gage span.

$$\frac{(\delta\lambda_{B1} - \delta\lambda_{B2})}{\lambda_{B0}} = \left(\frac{1}{n_1} \cdot \frac{\partial n_1}{\partial T} \cdot \frac{\lambda_{B1}}{\lambda_{B0}} - \frac{1}{n_2} \cdot \frac{\partial n_2}{\partial T} \cdot \frac{\lambda_{B2}}{\lambda_{B0}} \right) \cdot \delta T + \alpha_s \cdot \frac{(\lambda_{B1} - \lambda_{B2})}{\lambda_{B0}} \cdot \delta T + G_F \cdot \varepsilon_{s0} \quad (\text{eq.2})$$

$$\lambda_{B0} = \frac{(\delta\lambda_{B1} + \delta\lambda_{B2})}{2}$$

The Optical Circuits of Differential FBG Sensor

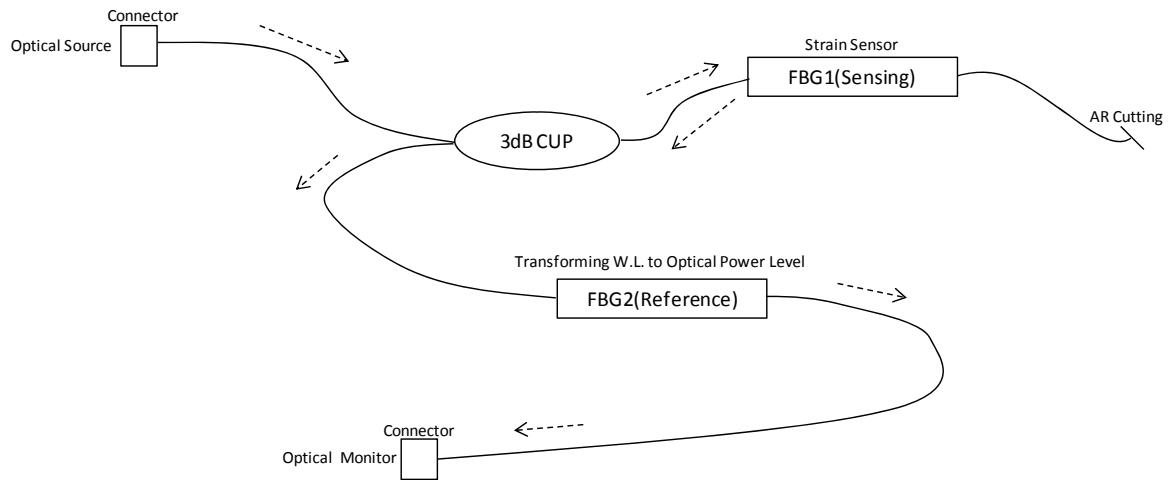

Fig-4 the differential FBG optical circuits

5. Specifications

■ Long Gage Sensor main unit

- 1) Measurement method ; the differential FBG optical circuit system
 $\lambda = 1550\text{nm}$, embedded internal temperature FBG sensor
- 2) Measurement items ;
 average strain between gage span, the displacement between gage span, Vibration waveform
 (See the Fig-8), crack, temperature around the gage sensor (option)
- 3) Range of the Measurement ; $\varepsilon = 0$ to $1000 \mu\text{-strain}$ @ $T_a = +25 \text{ deg-C}$, See the Fig-5
- 4) Temperature characteristic ; refer to the below data of the Fig-6
- 5) Sensitivity of simple FBG ; $1.2\text{pm}/\mu\text{-strain}$ with $\Delta \lambda = 1.4\text{nm}$
- 6) Resolution of strain ; $10 \mu\text{-strain}$
- 7) Accuracy of strain ; $10 \mu\text{-strain} / \text{step}$
- 8) Band of Response of net FBG ; 100Hz (provisional).
 Not included the response of the structural object.
- 9) Weights ; around 1.7 kg for the Long Gage Sensor main unit
 around 0.7 kg for the Optical fiber Terminal Box
 around 4.0 kg for the Optical source / the photodiode monitor module
- 10) Operating temperature ; -20 deg-C to $+40 \text{ deg-C}$
- 11) Span length of gage ; 1066mm
- 12) Strain Sensitivity Gain ; 1.1 times ($1066\text{mm} / 952\text{mm}$)
- 13) Design value of thermal expansion coefficient for the concrete structural objects
 $10 \mu\text{-strain} / \text{deg-C}$

The mismatch of the actual thermal expansion coefficient of the concrete structural objects to the design value will ingenerate the drift offset of the strain.

- 14) Correction function ;
 - Correcting the temperature drift of FBG sensor via the software signal processing.
 - Separating the part of temperature component from the total strain value of the concrete structural objects via the software signal processing. (optional)
- 15) Setting technique ; by the adhesive bond and by the anchor bolts
- 16) Network communications ; Transferring the data into the server computer via the internet (optional)
- 17) Management of the data ;
 - recording the sensor data, displaying the waveform, searching the database, the statistical processing, alarm functions via server computer or via user terminal computer.
- 18) Measurement Frequency ; constantly-monitoring
- 19) Power Supply ; AC 100V / External supplying
- 20) Out-of-door Rack ; (optional) See the Pic-3
 - We can supply the Out-of-door Rack which houses the Optical source / the photodiode monitor module, the temperature measurement module (optional), the communication equipments (optional), UPS (optional).
- 21) Judging alarm software functions ; See the Fig-5
 - Cracking alarm on the exceeding of 200 μ -strain
 - Broken alarm as to the reinforcing steel bar on the exceeding of 800 μ -strain
- 22) Block diagram of Long Gage Sensor Structural Health Monitoring System ; See the Fig-10

■ Optical source / the photodiode monitor module

- 1) Optical source ; SLED, B.W.=55nm(typ), Pout \geq +3dBm @BOL, See the Fig-9
- 2) Optical Receiver ; InGaAs PIN Photo Diode (4-ch), λ =1550nm
- 3) Photo Diode Amplifier ; Log Amp P.D. Board OEL8304LP
- 4) Analog Output Ports ; Output of Log Amp / BNC (4-ports)
- 5) ADC (Analog to Digital Converter) ; 12bits (4-ch), USB interface
- 6) Power Supply ; AC 100V, 50Hz to 60Hz
- 7) Operating temperature ; 0 to +50 deg-C
- 8) Application Software ;

ADC interface, Displaying the waveform of P.D. received signals, Calculating the conversion of received signals into the optical power, Calculating the look-up-table of strain values, Saving the data, Loading the data, Transferring the data via network, Judging alarm, Correcting the temperature drift of FBG sensor(optional), Separating the part of temperature component from the total strain value of the concrete structural objects(optional), Calculating the temperature correlation coefficient of the concrete structural objects(optional)

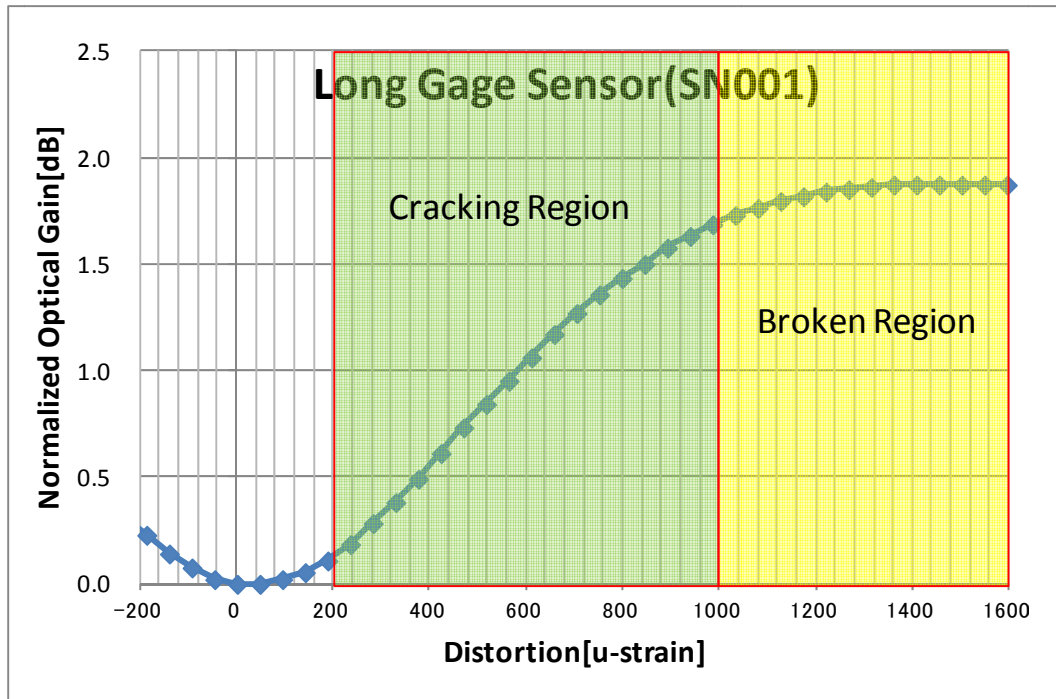

Fig-5 Measuring-strain characteristics of the differential FBG sensor

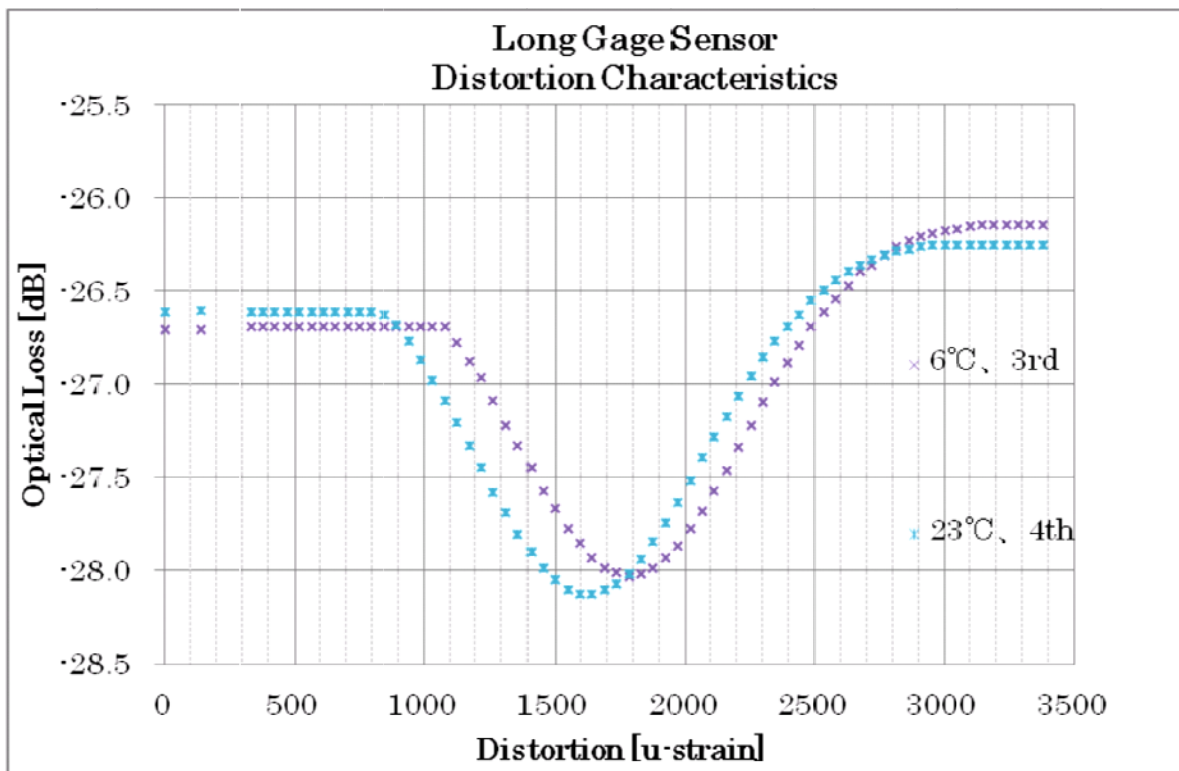

Fig-6 Temperature characteristics of the differential FBG sensor without correction

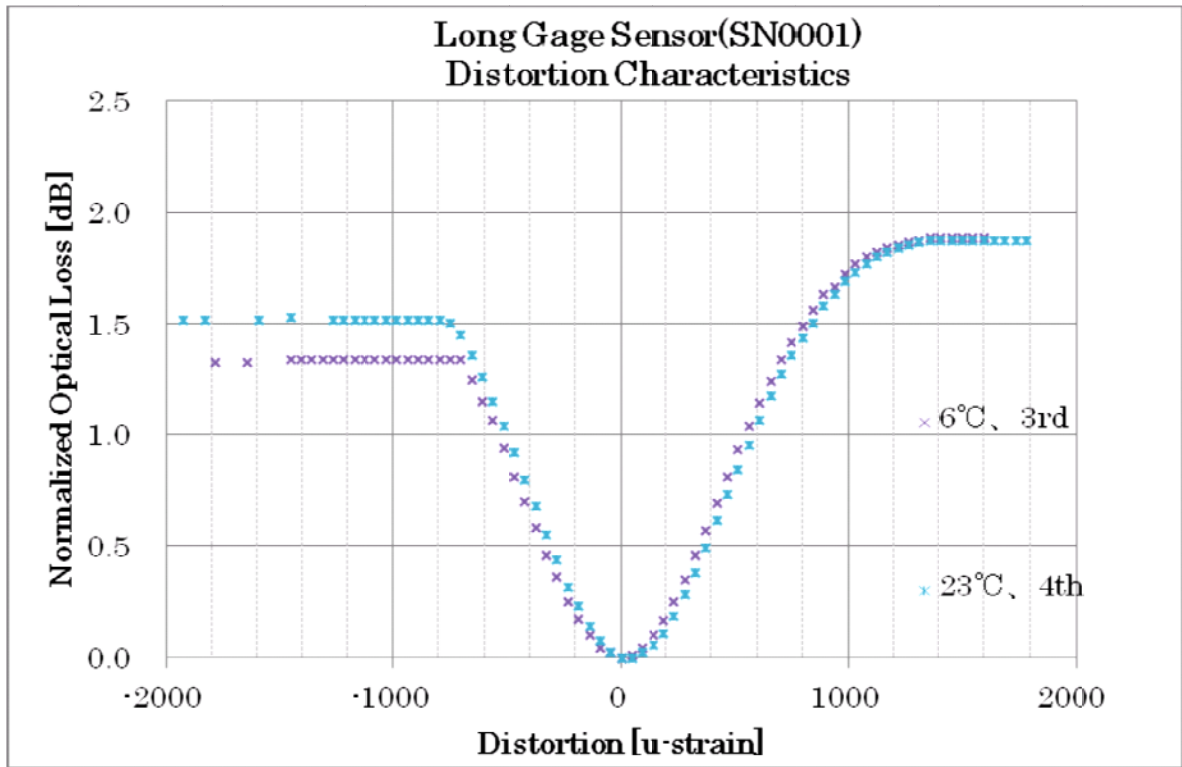

Fig-7 Temperature characteristics of the differential FBG sensor with correction

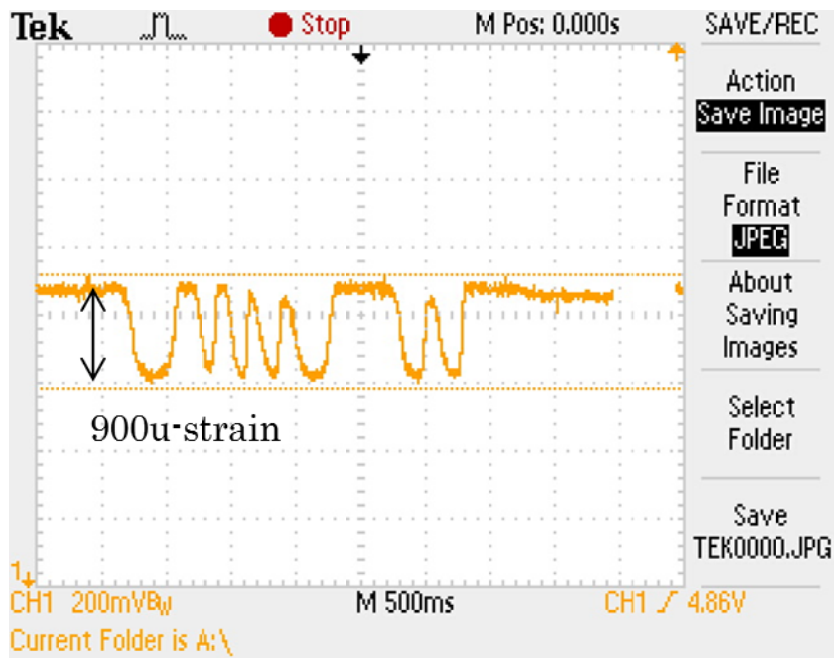

Fig-8 Waveform characteristics of the differential FBG sensor
 $\epsilon = 900 \text{ u-strain}$, pushed by hand's force

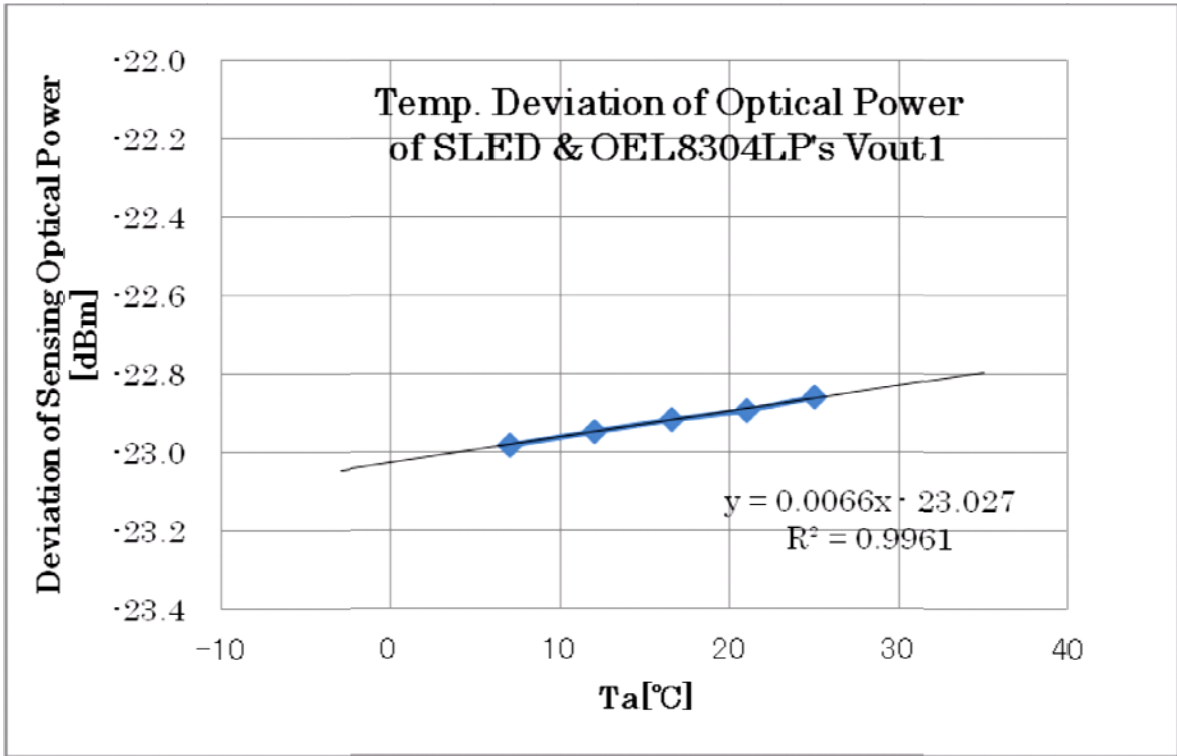

Fig-9 Temperature characteristics of the optical source SLED (0.007dB / deg-C)



Pic-3 Out-of-door Rack (RCJ60-610Y-P10A ; 680mm*680mm*1081mmH)

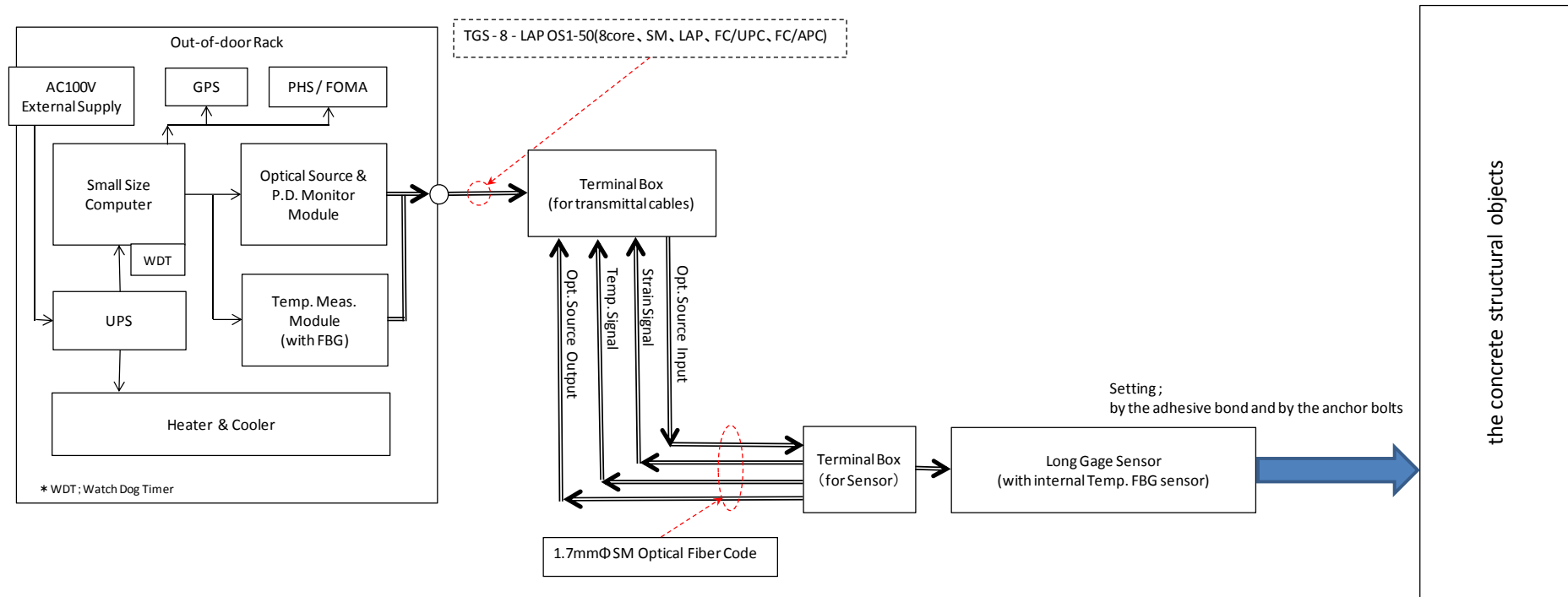

Fig-10 Total setting example of Long Gage Sensor Structural Health Monitoring system

6. Application Proposal of our Long Gage Sensor Structural Health Monitoring system

6.1 Example of the setting the Long Gage Sensor onto the concrete structural objects

The setting of the Long Gage Sensor main unit and of the optical fiber terminal box will be done by the adhesive bond and by the anchor bolts. See the Pic-4. And then Long Gage Sensor systems are going to start monitoring the degradation of the concrete structural objects since these settings.

If you hope to separate the part of temperature component from the total strain value of the concrete structural objects, you have to measure the temperature characteristics of the strain for the actual concrete structural objects with no live load in twice both in the case of low temperature T_{low} and of the high temperature T_{high} . It is desirable to keep the difference of $(T_{high} - T_{low})$ more than 20deg-C. The PC application software provides to users the function mode of the separating the temperature component from the total strain value, and of calculating the temperature correlation coefficients.



Pic-4 Setting the long gage sensor main unit and terminal box onto the concrete block object

6.2 Application Proposal of monitoring the degradation of the concrete bridges

The design of the concrete bridges estimates their own dead-loads, the vehicle live-loads, the tolerance of stress, their expected lifetime and keeps the safety of the bridges for long term. After their lifetime, the concrete bridges occur the cracks and will be degrading the decrepit and finally will lead to be broken. Actually, even though the concrete bridges have not reached the lifetime, there has be occurred the degradations and the collapses of the concrete structures via the aging of the concrete materials or via the fractures of the PC steel wires or via the wreck yield of the reinforcing steels. Our Long Gage Sensor Structural Health Monitoring system is very useful and powerful for user to monitor the degradation of the concrete bridge.

The setting position of the long gage sensor main unit onto the bridges is the center of the main girder between the bridge piers. (See Fig-11) This setting center position of the bridge is having the maximum bending moment by their-own dead-loads and by vehicle live-loads. The setting center position with maximum bending moment effects the maximum sensitivity of the stress-strain via these loads to the long gage sensor.

It is shown the actual situations of cracks and of the degradations at the decrepit concrete bridges in the Pic-5 to the Pic-7. It is interesting to see the fact that the directions of the cracks via the alkali-aggregate reaction are different to the directions of the stress-strain cracks.



Pic-5 Decrepit Prestressed Concrete (PC) Bridge

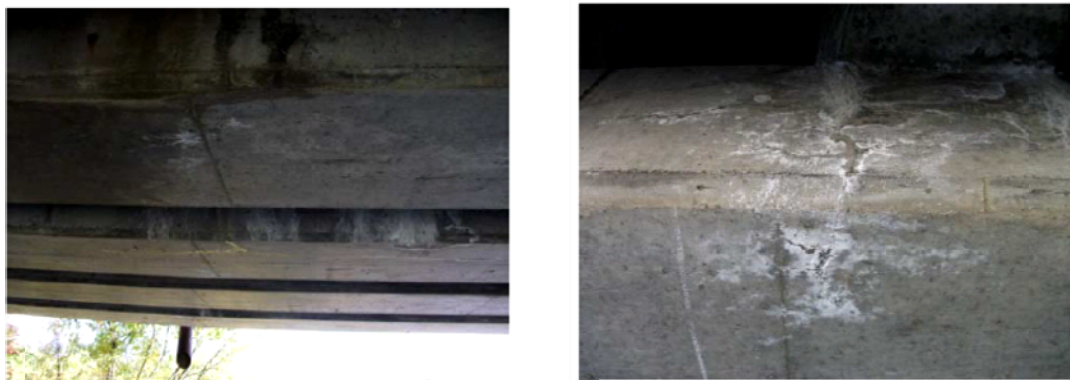

Pic-6 Stress-strain cracks



Pic-7 Cracks via the alkali-aggregate reaction

6.3 Application Proposal of monitoring the degradation of the tunnel

The tunnel takes the heavy-load and the stresses from the surrounding earth pressures, and ingenerates the deformation of their shapes. Monitoring the deformation of the tunnel for long-term via our Long Gage Sensor Structural Health Monitoring system provides the safety and brings hugely significant benefits to users. It is shown the application example of long gage sensor set onto the tunnel in the Fig-13.



Pic-8 Situations of cracks and of the degradation of the tunnel
And setting of the long gage sensor (old version) onto the concrete wall of the tunnel

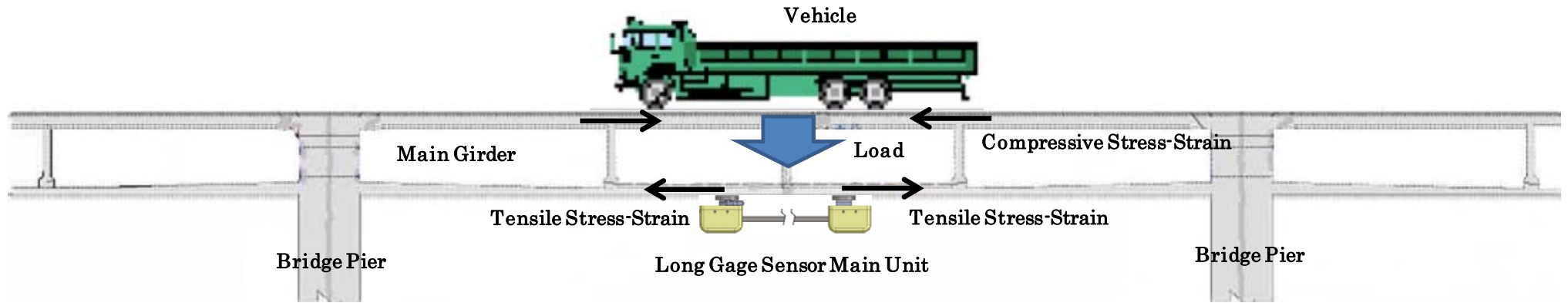

Fig-11 Application example of long gage sensor set onto the concrete bridge (traverse section)

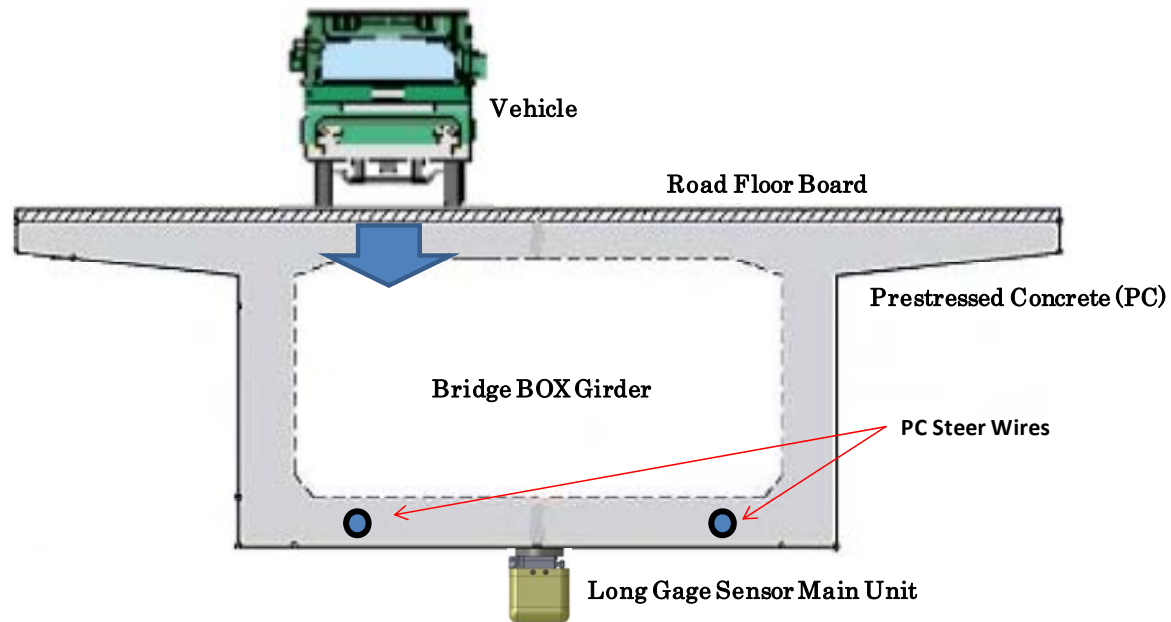

Fig-12 Application example of long gage sensor set onto the concrete bridge (cross-section)

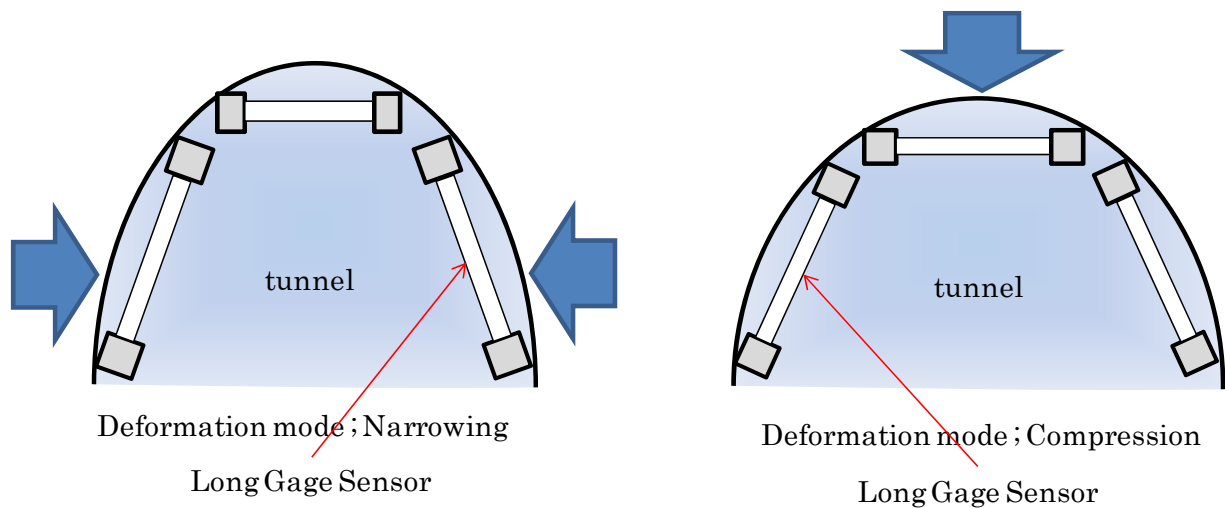

Fig-13 Deformation mode of the tunnel
 and the application example of long gage sensor set onto the tunnel

6.4 Application Proposal of monitoring the degradation of the Dam

The Dam drains a large amount of sand periodically via the sand clearing route. At this time, the concrete walls of the sand clearing route has been imposed on the heavy stresses by the Muddy sand stream, and may has been damaged deeply. Our Long Gage Sensor Structural Health Monitoring system is very useful and powerful for user to monitor the degradation and the damages of the concrete structural objects of the Dam. It is needed to set the long gage sensor main unit as close as possible at the position of the concrete walls which ingenerate the maximum bending moment and the maximum sensitivity of the stress-strain. See the Pic-9 and the Fig-14.

■ Technical question to ;

Opto-Electronic Engineering Laboratory Corporation / ogawa@optoelec-engineering.com

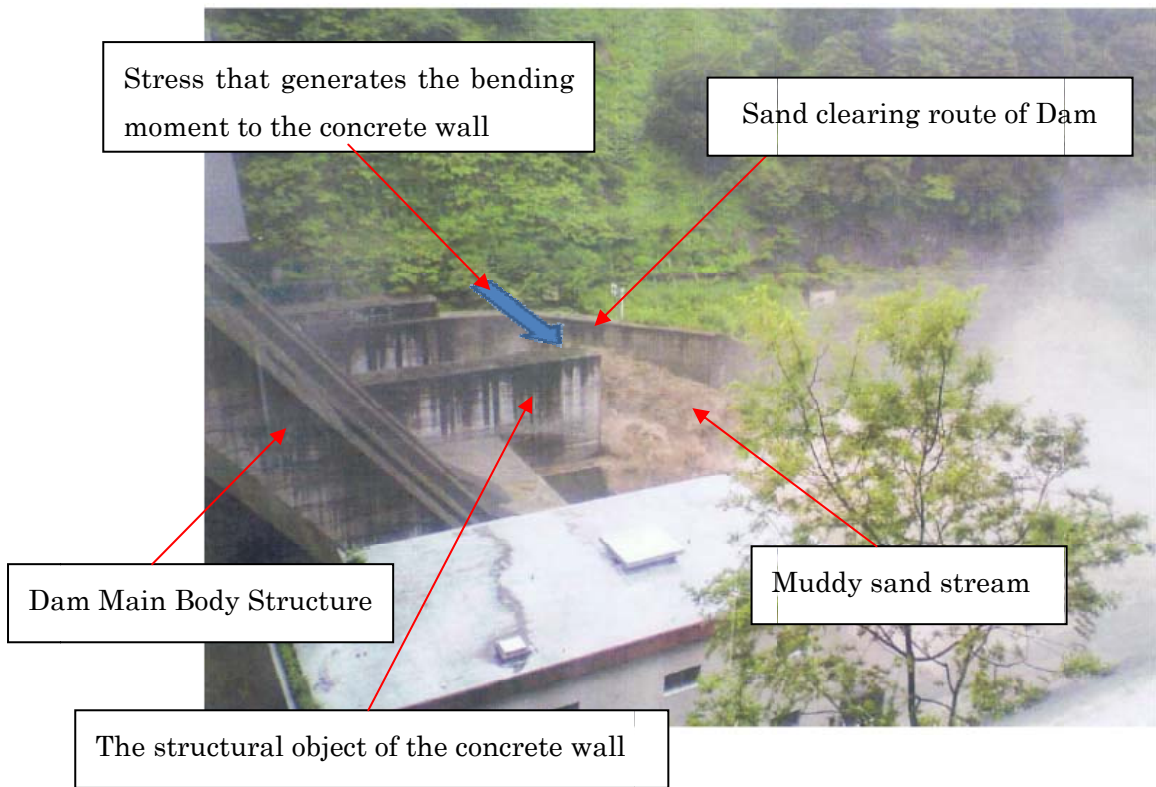

Pic-9 Sand clearing route of Dam

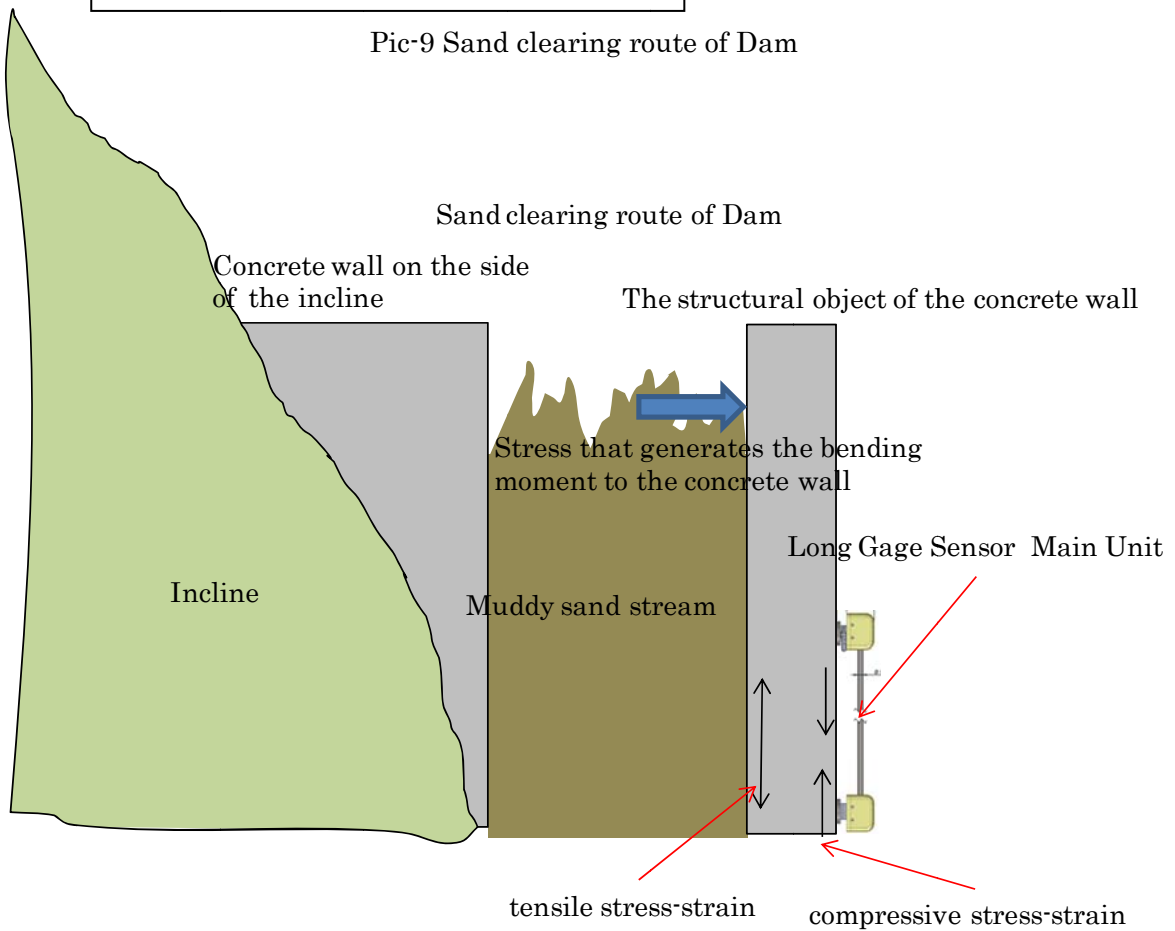

Fig-14 Application example of long gage sensor set onto the Dam structural object